

# Instructions

# P

## GB1400 gigaBERT Test Set Calibration Procedure (Kit PN 020-2326-00)

075-0473-00

*Note: This calibration procedure is only valid for those transmitter units of serial number 9310029 or higher. This calibration procedure is only valid for those receiver units of serial number 9611007.*

### **Warning**

The servicing instructions are for use by qualified personnel only. To avoid personal injury, do not perform any servicing unless you are qualified to do so. Refer to the Safety Summary prior to performing service.

Copyright © Tektronix, Inc., 1999. All rights reserved. Licensed software products are owned by Tektronix or its suppliers and are protected by United States copyright laws and international treaty provisions.

Use, duplication, or disclosure by the Government is subject to restrictions as set forth in subparagraph (c)(1)(ii) of the Rights in Technical Data and Computer Software clause at DFARS 252.227-7013, or subparagraphs (c)(1) and (2) of the Commercial Computer Software - Restricted Rights clause at FAR 52.227-19, as applicable.

Tektronix products are covered by U.S. and foreign patents, issued and pending. Information in this publication supersedes that in all previously published material. Specifications and price change privileges reserved.

Printed in the U.S.A.

Tektronix, Inc., P.O. Box 1000, Wilsonville, OR 97070-1000

TEKTRONIX and TEK are registered trademarks of Tektronix, Inc.

## Calibration Procedure

The calibration procedure may only be performed by qualified personnel. Any questions regarding this procedure or those units covered by this procedure should be directed to the factory Service Center at: (978) 244-4262.



---

**WARNING:** *The following servicing instructions are for use by qualified personnel only. To avoid personal injury, do not perform any servicing unless you are qualified to do so.*

---



---

**CAUTION:** *To prevent damage to static sensitive components, all work must be performed by a trained technician. Work must be performed at a static free workstation, making sure all proper static protection measures have been taken.*

---

This procedure describes the tests and pass/fail criteria required for calibration-level verification of the GB1400 system. The procedure uses the GB1400 System Test Software. Additional tests are outlined in this document that are not covered by the Test Software. These tests must be performed manually.

The first half of the procedure verifies the calibration of the GB1400 unit. The second half of the procedure provides instructions on how to calibrate the unit in the case that the calibration of the unit is found to be out of specification.

The next section, *Preparation*, describes the required equipment, loads the test software, and prepares everything for the actual testing.

## Preparation

This section provides instructions for preparing the unit for testing. These preparations include gathering the proper equipment and downloading the test software.

### Required Equipment

The following equipment is required to test and calibrate the GB1400 using this procedure.

- ❖ Tektronix CSA803 Signal Analyzer with sampling head
- ❖ Tektronix GB1400 Transmitter (calibrated)
- ❖ Tektronix GB1400 Receiver (calibrated)
- ❖ Frequency Counter (HP5386A, 53181A, or equivalent)
- ❖ Digital Multimeter with probes (Fluke 73, or equivalent)
- ❖ Personal computer, Intel 486 or better, with GPIB Interface card and drivers
- ❖ Three IEEE-488 cables
- ❖ Two SMA m-f 20dB (DC-26.5GHz) scope attenuators (HP 33340C or equivalent)
- ❖ One SMA m-f AC coupler
- ❖ One 50 ohms, SMA m-m scope calibration cable
- ❖ Four matched 50 ohms, SMA m-m coaxial cables (no greater than 2 feet long)
- ❖ One 50 ohms, SMA m-m coaxial trigger cable (no greater than 3 feet long)
- ❖ One SMA m-m feedthrough
- ❖ One SMA f-f feedthrough
- ❖ One male SMA 50 ohms-to-ground terminator
- ❖ Phillips screwdriver
- ❖ One small flat-bladed screwdriver or plastic coated tweeker (Marshall PN 8608 or equivalent)

### Conventions

The term '*the scope*', unless otherwise specified, refers to the CSA803 signal analyzer with sampling head and 20dB attenuators attached to channel 1 and channel 2.

## Test Software

The test software required for this procedure is on the diskette (PN 080-0725-00) that accompanied this procedure.

### System Requirements

- ⇒ An IBM PC/XT/AT (or compatible) computer with at least 640 kilobytes of memory and MS-DOS 3.1 or later operating system. Monitor type can be Color or Monochrome, Graphics are required.
- ⇒ One of the following communications interfaces:
  - GPIB - National Instruments GPIB board or equivalent. (GPIB.COM must be activated by CONFIG.SYS, see National Instruments documentation) or
  - HPIB - Hewlett Packard 82335 Interface Board or equivalent at any select code



---

***Note:** Because the program will automatically configure to the type of GPIB board that is installed (if one is installed), the program must exercise the software drivers that are associated with the board to see if the board responds. If the program attempts to use a Hewlett Packard GPIB board (HPIB), and no HPIB board is present, a memory corruption may cause the computer to lockup or crash because of a conflict with the DOS memory manager EMM386. At the same time, a properly installed HPIB board at Select Code 7 uses upper memory from DC00-DFFF, and EMM386 must be informed of this.*

*If a HPIB board is being used, then the firmware download program must be invoked using the “-h” switch, for example, **BERT -h**. Again, if this switch is used without a properly installed HPIB board, the PC may lockup or crash.*

*An HPIB board installed at Select Code can be made compatible with EMM386 by adding the following to the DEVICE = EMM386 command in CONFIG.SYS - “X=DC00-DFFF”*

---

### Installation

Create a directory on the hard-drive called “BERT”. Copy the diskette contents into this directory. The executable file that runs the test software is called “BERT.exe”. Type in “BERT 1400” at the DOS prompt to start the test software.

## Features

The test program, BERT.EXE is a DOS executable program that performs verification tests on the calibration and functionality of Microwave Logic gigaBERT-1400 Transmitter and Receiver pairs. These tests are recommended to be used after the calibration of either unit, Transmitter or Receiver, or to ascertain whether calibration is required. The test program can also be executed before and after calibration to provide historical data.

Three features are available while the tests are running. These features are Pause on Error, Pause, and Quit. Pressing ALT+P will toggle the pause on error function. This feature causes the test to stop running in the event of a failure. The screen will display “Paused on Error - press a key” if a failure occurs while this feature is enabled. Pressing any key on the computer keyboard (except for Q, ALT, CTRL, and ESC) will resume the test. Pressing “Q” at any time during the test will cause the test program to quit and return to DOS. Pressing F2 at any time during the test will cause the test program to pause until any key on the computer keyboard (except for Q, ALT, CTRL, and ESC) is pressed.

Test results for the current test are always written to a file called BERT1400.DAT in the root directory of the hard drive (C:). When a new test is started, BERT1400.DAT is renamed BERT1400.D01 and the new test results are written to BERT1400.DAT. The test results for the last fifty tests are kept on the hard drive, named BERT1400.DAT and BERT1400.D01 to BERT1400.D49, each time renaming all of the files so that the newest test data is contained in the BERT1400.DAT file, then BERT1400.D01, D02, D03, etc.

If the menu selection to copy the test results to the floppy disk drive (A:) is enabled, the results will be written to a directory on the A-drive (A:) called TEST. The file names for these test results will reflect the type of test that is run. These filenames are AUTOSRCH, CLOCK\_4, WAVEFORM, AMPOFFS, and DUTYCYCL. The suffix of the test file will be either .PAS or .FAI, depending on whether the test passed or failed. For example: AUTOSRCH.PAS indicates that the Autosearch test passed; CLOCK\_4.FAI indicates that the Clock/4 test failed. These test files will be overwritten if the test is rerun with the same outcome. The reason being that the files are copied to the floppy disk using the DOS XCOPY command and if the filename is identical, the old file will be overwritten.



---

*Note: If this option is enabled, the test results are still written to the C-drive, as well as the requested A-drive.*

---

## Calibration of the Scope

Before adjustments are made to the units, the scope must be calibrated to ensure that the readings are accurate. If the scope is not properly calibrated, it may make the calibration verification of the unit invalid. To accomplish the calibrations of the scope, a calibration cable, a SMA 50 ohms-to-ground terminator, two 20 dB attenuators, and the set of four matched cables are required.

First remove all cables and adapters from channels 1 and 2 of the scope. Press the UTILITY button and then touch PAGE TO on the screen. There are three different menu selections that must be calibrated. These calibrations must be done in the order given below.

### Gain

1. Touch GAIN and select channel 1.
2. Connect the calibration cable between the CALIBRATION OUTPUT and channel 1.
3. Touch AUTOMATIC CALIBRATION and then PROCEED.
4. When the scope finishes, touch STORE CONSTANTS.



---

**NOTE:** *This step is very important because with this command the adjustments that the scope has now made are committed to its memory. If you neglect to store the constants, you essentially never calibrated the scope.*

---

5. Disconnect the cable from channel 1 and select channel 2 on the screen.
6. Touch AUTOMATIC CALIBRATE and then PROCEED.
7. When the scope finishes, touch STORE CONSTANTS.
8. Disconnect the calibration cable completely and exit the GAIN menu.

**Offset**

1. Touch OFFSET and select channel 1.
2. Connect the 50 ohms-to-ground terminator to channel 1.
3. Touch AUTOMATIC CALIBRATE and then PROCEED.
4. When the scope finishes, touch STORE CONSTANTS.
5. Disconnect the terminator from channel 1 and select channel 2 on the screen.
6. Connect the terminator to channel 2.
7. Touch AUTOMATIC CALIBRATE and then PROCEED.
8. When the scope finishes, touch STORE CONSTANTS.
9. Disconnect the terminator from channel 2 and exit the Offset menu.

**Delay Adjust**

1. Connect the 20 dB attenuators to channels 1 and 2 of the scope.
2. Using the matched set of four cables, connect one of the cables to channel 1 of the scope. Connect another of the cables to channel 2 of the scope.
3. Connect the channel 1 cable to CALIBRATION OUTPUT of the scope.
4. Touch DELAY ADJUST and then select channel 1.
5. Touch MEASURE REFERENCE CHANNEL and then PROCEED.



*Note: Channel 1 is always the reference channel.*

---

6. When the scope is finished, disconnect the cable from CALIBRATION OUTPUT and select channel 2 on the screen.
7. Connect the channel 2 cable to CALIBRATION OUTPUT.
8. Press AUTOMATIC CALIBRATE and then PROCEED.
9. When the scope is finished, disconnect the cable from CALIBRATION OUTPUT.
10. Disconnect the cables from channels 1 and 2 of the scope.

## Verification

Now that the preparation is complete, the calibration may be verified. The calibration verification contains a number of procedures, some manual and some using the test software. Follow the procedures below to verify the calibration of the unit under test. Allow the GB1400 Transmitter and Receiver, the scope, and the frequency counter at least twenty minutes to warm-up before beginning the verification testing. The equipment requires a warm-up time to allow the components of the instruments to settle at room temperature. If this time is not allotted then the test results may be flawed.

### Functionality Verification

This section of the procedure verifies the basic functionality of the unit. The section consists of a GPIB controlled test that verifies the unit operates correctly. Both the GB1400 transmitter and GB1400 receiver are required for this test. The transmitter and receiver are linked together. Then a GPIB test runs through a series of patterns and set conditions to verify that the units respond correctly. This verification test determines if the units can be calibrated. If this test does not pass, then the unit has a problem other than calibration. Four matched cables and three GPIB cables are the only required equipment.



---

*Note: When the transmitter and receiver are linked together, the cables must always be matched.*

---

1. On the transmitter, remove the terminators from CLOCK BAR and DATA BAR.
2. Using the four matched cables, link the transmitter and receiver together as follows.
  - A. Connect the transmitter CLOCK OUT to the receiver CLOCK IN.
  - B. Connect the transmitter CLOCK BAR OUT to the receiver CLOCK BAR IN.
  - C. Connect the transmitter DATA OUT to the receiver DATA IN.
  - D. Connect the transmitter DATA BAR OUT to the receiver DATA BAR IN.
3. Link the transmitter, the receiver, and the computer together with GPIB cables. *Make sure everything is securely connected.*
4. Verify that the GPIB address of the transmitter is 15 by pressing GPIB ADDRESS on the front panel. The address will appear in the bottom left-hand corner of the display. (Address 15 is the transmitter's default setting).
5. Verify that the GPIB address of the receiver is 14 by pressing GPIB ADDRESS on the front panel. The address will appear in the bottom left-hand corner of the display. (Address 14 is the receiver's default setting).

6. On the computer keyboard, type 'BERT 1400' and then <ENTER>.



*Note: If the GPIB interface is a Hewlett Packard HPIB board, the program cannot be executed by typing BERT1400 and then <ENTER>. With an HPIB board, the program must be executed by typing BERT 1400 -H and then <ENTER>. There is a space between BERT and switch -H. The reason for this switch when using a Hewlett-Packard HPIB board is to prevent a lock-up or crash of the PC because of a conflict between HPIB and the DOS operating system memory manager (EMM386).*

7. On the computer screen, the main menu of the test software is displayed as shown in Figure 1.

F1	Clock and Data Waveforms Test	DISABLED
F2	Clock and Data Duty Cycle Test	DISABLED
F3	Clock/4 Test	DISABLED
F4	Autosearch Test	DISABLED
F5	Data Amp/Offset/VThresh Test	DISABLED
F6		
F7	Write Test Results to A:	DISABLED
F8		
F9	Run!	
F10	Exit	

**Figure 1: Main menu of the test software**

8. On the computer keyboard, press F4 on the main menu to select the Autosearch Test and then press F9 to start the test.



*NOTE: If you wish the results to be written to the A-drive, also press F7 before pressing F9.*

9. The cable connection instructions are given at the beginning of each test as required. Verify, when these instructions appear on the screen, that the cable connections are correct. When all connections have been verified, press <ENTER> to continue the test.
10. As the test progresses, the test data will be displayed on the computer screen. When the test is complete, the software returns to the menu screen.

If the GB1400 successfully passed the test, then the unit is working properly and calibration may begin. Proceed to the next section, *Transmitter Verification*, to verify the calibration of the GB1400 Transmitter.

If the GB1400 did not successfully pass the test, then there may be a problem with the unit. Perform this test again paying special attention to the set-up. If the GB1400 still fails, then there is a problem with the unit and it must be returned to the Factory Service Center for repair. The Customer Service Center may be reached at 1-800-962-9738.

## Transmitter Verification

In this section, the calibration of the GB1400 Transmitter will be verified. The procedure consists of several automated tests, which will check waveform quality, duty cycle, and signal quality. There are also several quick manual checks, which simply verify functionality of a particular aspect of the unit.

### Waveform Verification

The signal quality of the clock and data signals is examined in this section. The transmitter is linked to a scope and run on GPIB using the test software provided. The scope with 20dB attenuators attached, the trigger cable, and the matched coax cables are the only required equipment.

1. On the front panel of the transmitter, connect CLOCK to channel 1 of the scope using one of the matched cables.
2. Using another of the matched cables, connect DATA of the transmitter to channel 2 of the scope.
3. Connect the trigger cable between PATTERN SYNC of the transmitter and DIRECT TRIGGER INPUT of the scope.



---

*Note: The DIRECT TRIGGER INPUT is always the trigger input that this procedure uses on the scope.*

---

4. Verify that the address of the scope is 8 (verify by pressing UTILITY and then touching GPIB/RS-232).
5. Link the computer, scope, and transmitter together with GPIB cables.
6. On the computer keyboard, type BERT 1400 and then press <ENTER> to start the test program.
7. On the main menu, press F1 to select the Waveform Test and then press F9 to start the test.



---

*NOTE: If you wish the results to be written to the A-drive, also press F7 before pressing F9.*

---

8. The cable connection instructions are given at the beginning of each test as required. Verify, when these instructions appear on the screen, that the cable connections are correct. When all connections have been verified, press <ENTER> to continue the test.
9. As the test progresses, the test data will be displayed on the computer screen. When the test is complete, the software returns to the menu screen.

If the transmitter successfully passed the test, then the waveform is within calibration. Proceed with the transmitter verification.

If the transmitter did not successfully pass the test, perform the test again paying special attention to the set-up. If the transmitter still fails, then the waveform needs to be calibrated. Proceed to the calibration section, *Transmitter Calibration*, and perform the Waveform Calibration procedure.



---

**NOTE:** *The waveform calibration is critical to a number of other calibrations. Due to the nature of the calibration, it is very sensitive and easy to upset. Be absolutely sure that the test failure is valid and not an operator error before proceeding to the calibration section.*

---

## Data Eye Crossing

This procedure verifies that the data eye crossing of the transmitter is within calibration.

1. Remove all cables from the scope and transmitter.
2. On the transmitter, set the frequency to 1405 MHz.
3. Set the clock and data amplitudes to 2.00V.
4. Set the clock and data offsets to -1.00V.
5. Set the data pattern to PN7.
6. Disconnect the ground terminator from DATA BAR.
7. Attach a SMA m-m adapter and a SMA f-f adapter to DATA BAR.
8. Connect channel 1 of the scope to DATA of the transmitter.
9. Connect channel 2 of the scope to DATA BAR of the transmitter.
10. Connect DIRECT TRIGGER of the scope to CLOCK of the transmitter.
11. On the scope, press UTILITY and the touch INITIALIZE on the scope screen.
12. Touch INITIALIZE on the scope screen.



---

**NOTE:** *The scope now disables all channels and reinitializes itself. The scope initialization is complete when the prompt, a solid red line, appears at the top of the screen.*

---

13. Press the two buttons on the sampling head (channel 1 first, then channel 2).





---

**NOTE:** *These buttons enable channels 1 and 2. You have just cleared the scope of any miscellaneous signals.*

---

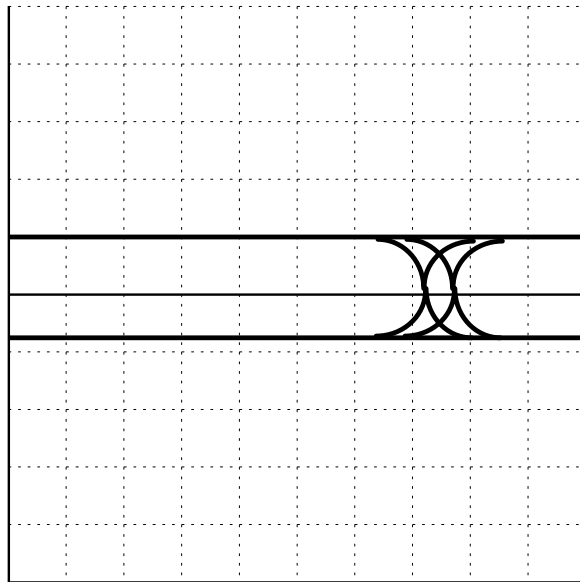
14. The scope screen should now show two waveforms looking similar to overlapping X's between two horizontal lines. Refer to Figure 2 for a sample of the waveforms at this point.
15. Touch the vertical arrow on the left side of the scope screen.
16. Using the top dial, adjust the vertical setting to 20 mV/div (setting is stated right below the arrow). The data eye displayed on channel 2 is now set so that it vertically fills the screen.
17. Touch the small data eye to change the controls to channel 1.
18. Using the top dial, adjust the horizontal setting to 50 ps/div (setting is the center number between the bottom of the grid and the top of the menu).



**Figure 2: Initial Data Eyes on the Scope Screen (PN7)**

19. Using the bottom dial, move the data eyes to the left until they are centered on the screen. The position setting should be around 21.6 ns (setting is the right hand number between the bottom of the grid and the top of the menu).
20. The center of the data eyes (the center of the “X”) should be around the center of the scope’s grid (this position is marked by a solid horizontal line and a small arrow on the left-hand side of the grid). Both of the data eyes should be as close to even with each other as possible. Due to the variance of the waveforms themselves and the inaccuracy of the human eye, they will not be perfectly even. Realistically, as long as the centers are close to equal, they are all right. See Figure 3 for a sample of a correct PN7 data eye.



**NOTE:** Use the data eye in Figure 3 as a standard. If the data eyes are closer than this, the calibration is fine. If the data eyes are farther out than this, the calibration is wrong and will need to be redone.

21. Now the data eye in a word pattern must be checked.
22. On the front panel of the transmitter, set the data pattern to WORD.
23. Set the WORD length to 01.
24. Set the WORD pattern to alternating 1’s and 0’s (word 55 - 01010101).
25. Using the same rules as for the PN7 data eye, check the data eyes on the scope verifying that the center of the data eyes are around the center of the scope’s grid. Refer to Figure 4 for a sample of the Word data eye.

If the transmitter successfully passed the test, then the data eye is within calibration. Proceed with the transmitter verification.

If the transmitter did not successfully pass the test, perform the test again paying special attention to the set-up. If the transmitter still fails, then the data eye needs to be calibrated. Proceed to the calibration section, *Transmitter Calibration*, and perform the Data Eye Adjustment procedure.

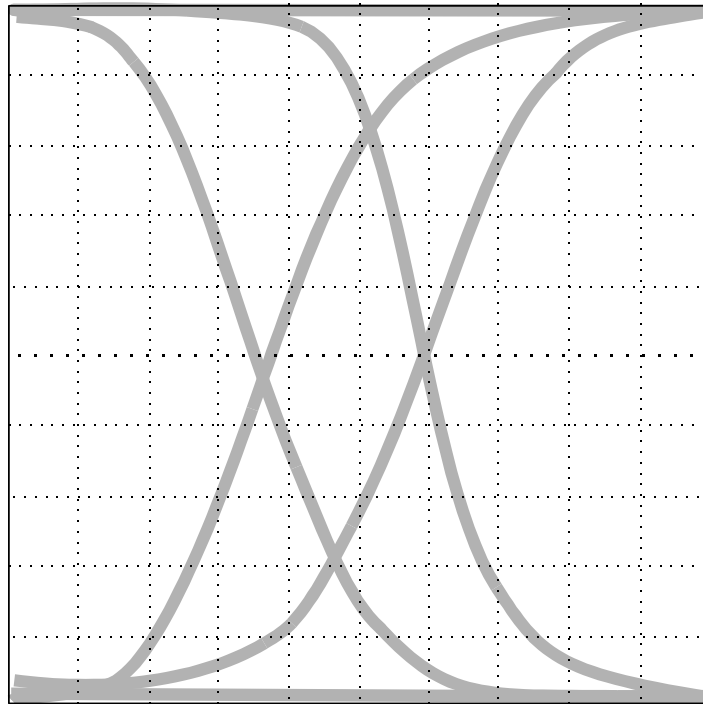

*Figure 3: Sample of a correct data eye crossing for PN7*

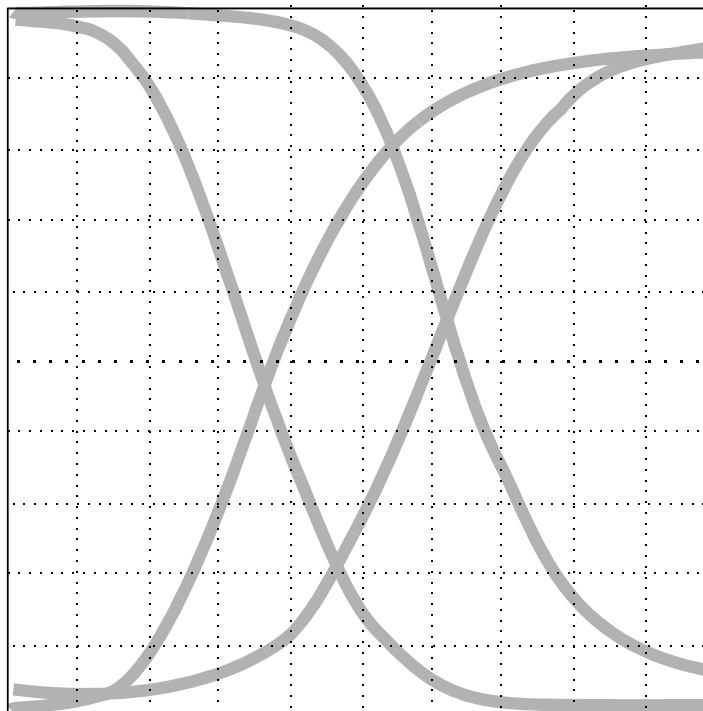

*Figure 4: Sample of a correct data eye crossing for WORD 55*

## Clock Duty Cycle Test

This procedure verifies that the clock symmetry, or duty cycle, of the transmitter is within specification. The transmitter is linked to the scope and run on GPIB using the test software provided. The matched cables and the trigger cable are the only required equipment.

1. Disconnect all cables and adapters from the transmitter. Reconnect the terminator to DATA BAR.
2. Connect channel 1 of the scope to CLOCK of the transmitter.
3. Connect the trigger cable of the scope to PATTERN SYNC of the transmitter.
4. Link the computer, the scope, and the transmitter together with GPIB cables.
5. On the computer keyboard, type BERT 1400 and then press <ENTER> to start the test program.
6. On the main menu, press F2 to select the Clock & Data Duty Cycle Test and then press F9 to start the test.



---

*NOTE: If you wish the results to be written to the A-drive, also press F7 before pressing F9.*

---

7. When the instructions appear on the screen, verify that the cable connections are correct. When all connections have been verified, press <ENTER> to continue the test.
8. The computer will display test data on the screen as the test progresses. When the test is complete, the software returns to the main menu screen.

If the transmitter successfully passed the test, then the clock duty cycle is within calibration. Proceed with the transmitter verification.

If the transmitter did not successfully pass the test, perform the test again paying special attention to the set-up. If the transmitter still fails, then the clock duty cycle needs to be calibrated. Proceed to the calibration section, *Transmitter Calibration*, and perform the Clock Duty Cycle Calibration procedure.

## Clock Accuracy Test

This procedure verifies that the clock frequency is correct. There is no GPIB test for this verification. The procedure will link the unit to a frequency counter and scan the frequencies to ensure there is no drift. The only required equipment is a coax cable and the frequency counter.

1. Remove all cables from the transmitter.
2. Attach a cable between the frequency counter and CLOCK of the transmitter.
3. On the transmitter, set the frequency to 1405 MHz and verify that the frequency counter also reads 1405 MHz.
4. On the transmitter, scroll through the frequencies in 100 MHz steps, verifying that each frequency is correctly reflected on the frequency counter.

If the transmitter successfully passed the test, then the clock frequency is within calibration. Proceed with the transmitter verification.

If the transmitter did not successfully pass the test, perform the test again paying special attention to the set-up. If the transmitter still fails, then the clock frequency needs to be calibrated. Proceed to the calibration section, *Transmitter Calibration*, and perform the Clock Accuracy Adjustment procedure.

## Clock/4 Test

This procedure verifies that the CLOCK/4 output is working properly. There is no calibration for the CLOCK/4. This procedure is a performance test only. The transmitter is linked to the scope via GPIB and then a performance test is run on GPIB using the software provided. The scope, a coax cable, and the trigger cable are the only required equipment.

1. Remove all cables from the transmitter.
2. Connect channel 1 of the scope to CLOCK/4 of the transmitter.
3. Connect the trigger cable of the scope to PATTERN SYNC of the transmitter.
4. Link the computer, the scope, and the transmitter together with GPIB cables.
5. On the computer keyboard, type BERT 1400 and then press <ENTER> to start the test program.
6. On the main menu, press F3 to enable the Clock/4 Test and then press F9 to start the test.



---

*NOTE: If you wish the results to be written to the A-drive, also press F7 before pressing F9.*

---

7. When the instructions appear on the screen, verify that the cable connections are correct. When all connections have been verified, press <ENTER> to continue the test.
8. The computer will display test data on the screen as the test progresses. When the test is complete, the software returns to the main menu.

If the transmitter successfully passed the test, then the CLOCK/4 output is working properly. Proceed with the transmitter verification.

If the transmitter did not successfully pass the test, perform the test again paying special attention to the set-up. If the transmitter still fails, then there is a problem with the CLOCK/4 output and the transmitter must be returned to the Factory Service Center for repair. The Customer Service Center may be reached at 1-800-325-2201.

## Pattern Sync Test

This procedure verifies that the PATTERN SYNC output is working properly. There is no calibration for the PATTERN SYNC. This procedure is a manual performance test only. The scope, a coax cable, and the trigger cable are the only required equipment.

1. Disconnect all cables from the transmitter.
2. On the transmitter, set the frequency to 1405MHz.
3. Set the word length to 000001 bytes.
4. Set the 8-bit word to single bit – 01 (LSB).
5. Set the data amplitude to 1.00V and the data offset to –0.50V.
6. Connect the trigger cable of the scope DATA of the transmitter.
7. Connect channel 1 of the scope to PATTERN SYNC of the transmitter.
8. Set the vertical position of the scope to 5mV/div and center the signal around zero.
9. Change the horizontal setting of the scope to 2ns/div.
10. Compare the pattern sync signal on the scope screen to the pattern sync signal given in Figure 5.

If the pattern sync signal on the scope screen is correct, then the PATTERN SYNC output is working properly. Proceed with the transmitter verification.

If the pattern sync signal is not correct, then there is a problem with the PATTERN SYNC output and the transmitter must be returned to the Factory Service Center for repair. The Customer Service Center may be reached at 1-800-962-9738.

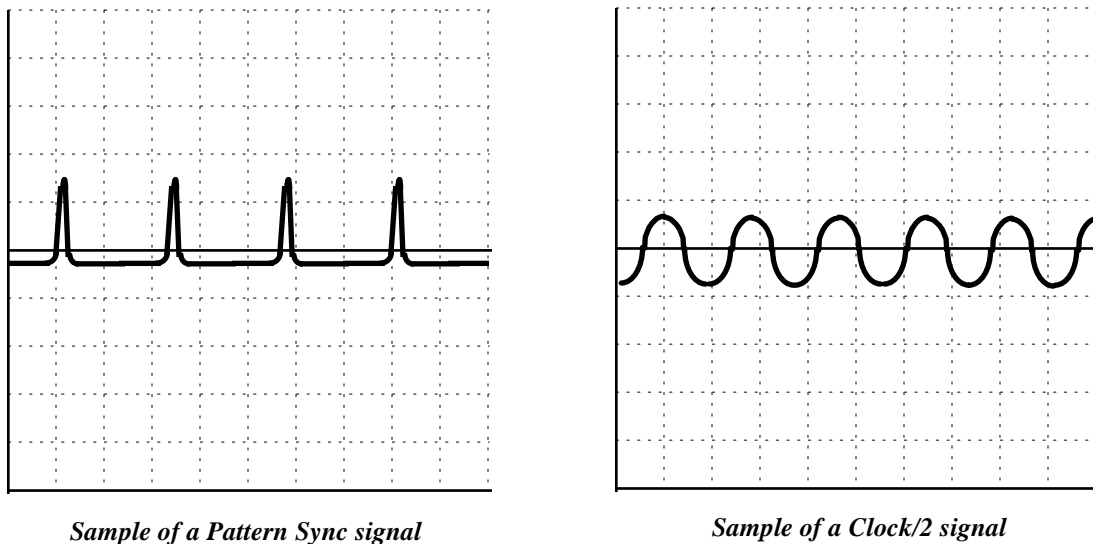

**Figure 5: Pattern Sync and Clock/2 signals**

**Clock/2 Test**

This procedure verifies that the CLOCK/2 output is working properly. There is no calibration for the CLOCK/2. This procedure is a manual performance test only. The scope, an AC coupler, a coax cable, and the trigger cable are the only required equipment.

1. Disconnect all cables from the scope and the transmitter.
2. Connect the AC coupler to channel 1 of the scope.
3. Connect a coax cable between channel 1 of the scope and CLK/2 on the rear panel of the transmitter.
4. Connect the trigger cable of the scope to PAT SYNC on the transmitter.
5. On the transmitter, set the frequency to 1405MHz.
6. Set the clock and data amplitudes to 2.00V.
7. Set the clock and data offsets to -1.00V.
8. Press PRBS and set the data pattern to PN7.
9. Compare the clock/2 signal on the scope screen to the clock/2 signal given in Figure 5.

If the clock/2 signal on the scope screen is correct, then the CLOCK/2 output is working properly. Proceed with the transmitter verification.

If the clock/2 signal is not correct, then there is a problem with the CLOCK/2 output and the transmitter must be returned to the Factory Service Center for repair. The Customer Service Center may be reached at 1-800-962-9738.

## Receiver Verification

In this section, the calibration of the GB1400 Receiver will be verified. The procedure consists of one automated test, which will check threshold levels of the receiver inputs. In order to test the receiver, a calibrated transmitter must be available for use.

### Threshold Verification

The input switching threshold levels for the receiver are examined in this section. The receiver is linked to a transmitter and run on GPIB using the test software provided. A GB1400 transmitter and the four matched coax cables are the only required equipment.

1. On the transmitter, remove the terminator from CLOCK BAR.
2. Using the four matched cables, link the transmitter and receiver together as follows.
  - A. Connect the transmitter CLOCK OUT to the receiver CLOCK IN.
  - B. Connect the transmitter CLOCK BAR OUT to the receiver CLOCK BAR IN.
  - C. Connect the transmitter DATA OUT to the receiver DATA IN.
  - D. Connect the receiver DATA BAR IN to VTHRESH on the rear panel of the receiver.
3. Link the transmitter, the receiver, and the computer together with GPIB cables.
4. On the computer keyboard, type BERT 1400 and then press <ENTER> to start the test program.
5. On the main menu, press F5 to enable the Data Amp/Offset/VThresh Test and then press F9 to start the test.



---

*NOTE: If you wish the results to be written to the A-drive, also press F7 before pressing F9.*

---

6. When the instructions appear on the screen, verify that the cable connections are correct. When all connections have been verified, press <ENTER> to continue the test.
7. The computer will display test data on the screen as the test progresses. When the test is complete, the display returns to the main menu.

If the test passes completely, the receiver threshold levels are within calibration. Proceed with the receiver verification.

If the test does not pass, perform the test again paying special attention to the set-up. If the receiver still fails, then the threshold levels need to be calibrated. Proceed to the calibration section, *Receiver Calibration*, and perform the Threshold Calibration procedure.

## System Calibration

This section calibrates both the transmitter and receiver. The first section, Preparation, prepares the unit for calibration. This section is the same for both receiver and transmitter. The two sections following Preparation are the Transmitter Calibration section and the Receiver Calibration section.

To perform these calibrations, the outside covers of the transmitter and receiver must be removed. The Preparation section that follows provides instructions for removing the outside covers and the inner EMI cover.

### Preparation

Perform this procedure before beginning any calibrations. This procedure removes the outside covers and the inner EMI cover of the transmitter. A Phillips screwdriver is the only required equipment.



**WARNING:** Before proceeding, disconnect the power cord from the line voltage source. Failure to do so could cause serious injury or death.

Study Figure 6, which defines the sides of the GB1400 as they are referred to by the procedures.

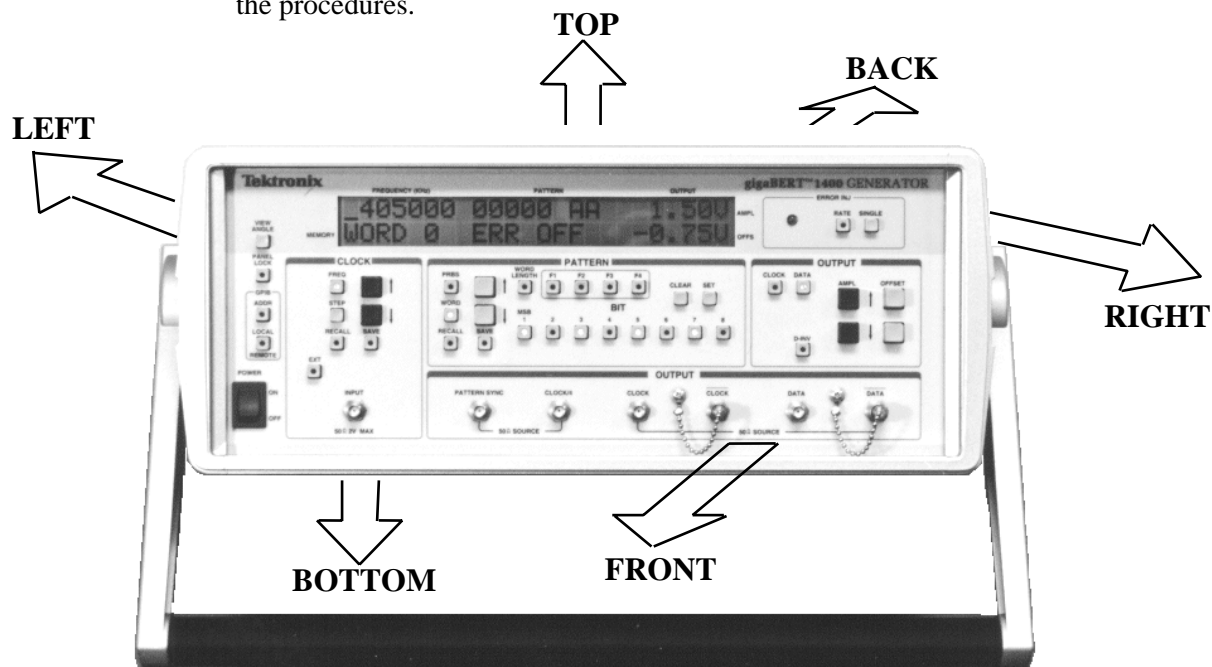

**Figure 6: GB1400 Series Test Set Orientation**

1. Disconnect all cords and cables from the unit, including the power cord.
2. Place the unit on the bench so that the front of the unit is facing you. Refer to Figure 6 for proper orientation.
3. Carefully peel off the four calibration void labels covering the four bezel screws found on the left and right sides of the front and back bezels.



***Note:** These labels will not be reused, but the screws will be. If some care is not taken in the removal of the labels, pieces of the label may get caught in the screw, making it unusable.*

4. Using the Phillips screwdriver, remove the four screws from the front and back bezels and set them aside. Refer to Figure 7, if required.

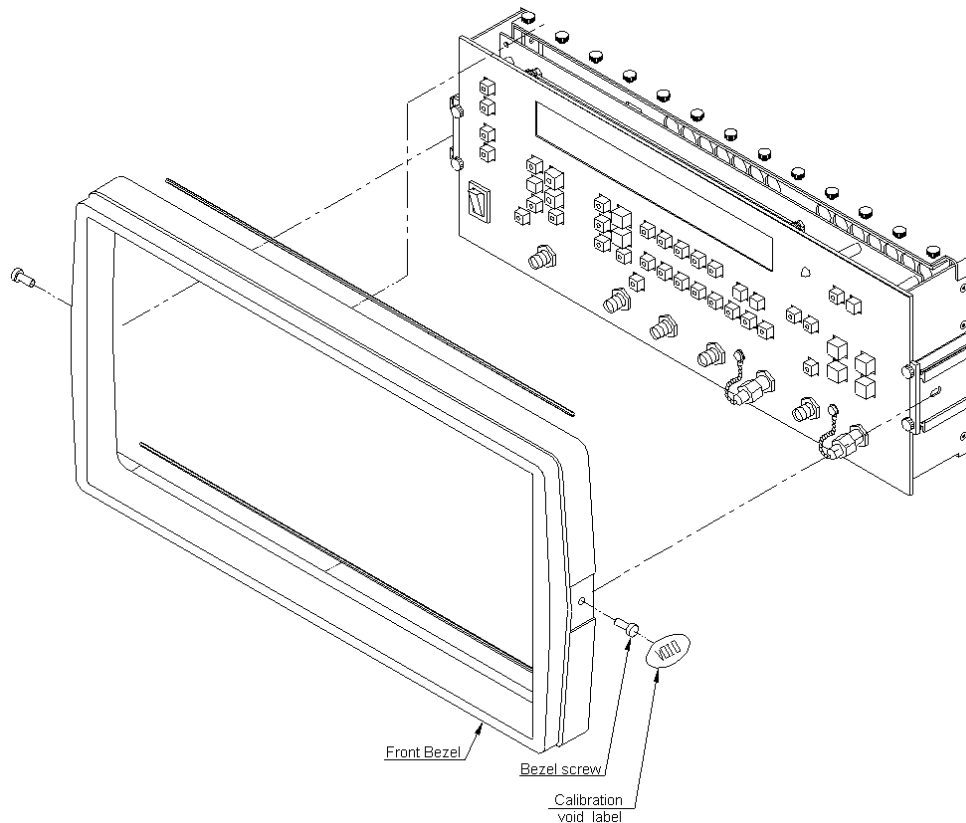

**Figure 7: Removal of bezels**

5. Once the bezel screws have been removed, lift off the front bezel and set it aside.
6. Remove the back bezel and set it aside.
7. Remove the top cover and set it aside.
8. Holding the side rails of the unit, lift it up and remove the bottom cover from underneath it. The outer covers of the GB1400 have now been removed.
9. Using the Phillips screwdrivers, remove all of the screws holding the top cover in place and put them aside. Lift the cover. You should now see the PCBs mounted within the chassis.

## Transmitter Calibration

Now that the GB1400 transmitter has been verified, those sections that failed must be calibrated. As in the Transmitter Verification section, each procedure is its own section. The Waveform Calibration must be done before the Data Eye calibration if both procedures need to be performed. Otherwise, all calibrations may be performed separately. Apply power to the transmitter and allow it at least twenty minutes to warm-up before beginning calibration.

### Waveform Calibration

Perform this calibration only if the Waveform Test failed. The scope, the trigger cable, the matched coax cables, and a tweaker are the only required equipment.

This calibration is broken into three segments. The first segment, Unit and Scope Set-ups, prepares the scope and the transmitter for calibration. The calibration is done manually and hence the instruments need to be set to a specific configuration before the manual adjustments may be made. The second segment is Clock Adjustments and is where the clock waveform is calibrated. The third is Data Adjustments and is where the data waveform is calibrated.

Before beginning, connect the trigger cable between the scope and PATTERN SYNC on the transmitter. Using the matched cables, connect channel 1 of the scope to CLOCK of the transmitter and connect channel 2 of the scope to DATA of the transmitter.

### *Unit and Scope Set-Ups*

1. Set the frequency of the transmitter to 805MHz.
2. Set the clock and data amplitudes to 0.50V.
3. Set the clock and data offsets to -1.00V.
4. Set the data pattern to WORD.
5. Set the WORD LENGTH to 01.
6. Set the WORD pattern to 10101010 (WORD - AA).
7. On the scope, set the following conditions.
  - A. Press UTILITY on the scope.
  - B. Touch INITIALIZE on the screen.
  - C. Touch INITIALIZE.
  - D. Press the two buttons on the sampling head (channel 1 first, then channel 2).
  - E. Touch the vertical arrow on the scope screen.
  - F. Using the top dial, set the vertical measurement to 50mV/div.
  - G. Select channel 1.
  - H. Using the top dial, set the vertical measurement to 50mV/div.
  - I. Touch the horizontal arrow.
  - J. Using the top dial, set the horizontal position to 500ps/div.
  - K. Press MEASURE.
  - L. Touch MEASUREMENTS on the scope screen.

- M. Select AMPLITUDE and MIN, then exit the MEASUREMENTS menu.
- N. Select channel 2.
- O. Touch MEASUREMENTS on the scope screen.
- P. Select PEAK-TO-PEAK and MIN, then exit the MEASUREMENTS menu.
- Q. Select channel 1. You are now ready to calibrate the clock amplitude and offset.

### *Clock Adjustments*

There are four different values that must be calibrated for the clock outputs. These values are compensation, interaction, amplitude, and offset. The compensation and interaction are set once. The amplitude and offset are set once and may be slightly adjusted at several other setting combinations.





---

*Note: It is imperative that these steps are done in the order that they are explained and only if necessary. Each of the adjustments affects the others. If one adjustment is wrong, all the adjustments are affected, making them all wrong. Make these adjustments only if absolutely necessary. If one adjustment appears to be correct, leave it alone and proceed to the next one. The waveform calibrations are very sensitive and can be set wrong very easily. Also, these pots were all adjusted at the factory, therefore if there is drift, the pot adjustments needed should be very small. If you are making major turn adjustments on the pots there is likely something else wrong.*

---

All of the pots necessary for this calibration appear on the Tx Amp board. Use Figure 8 as a reference guide for finding the Tx Amp board. Use Figure 9 as a reference guide to the calibration pots on the Tx Amp board.

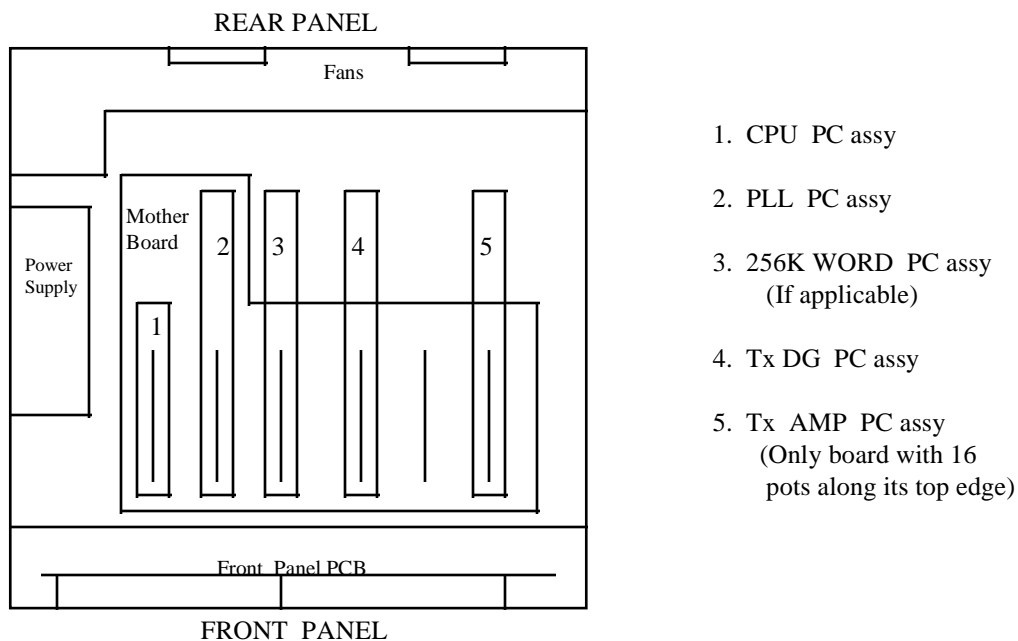
1. Clock compensation will be the first adjustment made. Compensation is used to minimize the overshoot of the signal while optimizing the rise and fall times of the signal. ***This adjustment also has the greatest effect on the amplitude and offset.*** If the compensation is over-adjusted, the other pots will not be enough to neutralize its effect on the waveform.
2. The compensation only needs to be adjusted if, during the waveform test, the clock failed one of the following conditions.
  - A. Rise Time
  - B. Fall Time
  - C. Overshoot
  - D. Undershoot
3. The pot that controls clock compensation is pot R14 and is labeled CLK EYE.
4. Set the clock waveform on channel 1 of the scope so that at least one full cycle is visible on the scope screen.
5. Carefully turn pot R14 and observe the waveform change shape. The desired signal shape is a wave that has the largest possible amplitude and an offset with a constant base line. Gauge the best position with your eye.



**Figure 8: Placement of PCBs inside the transmitter chassis**

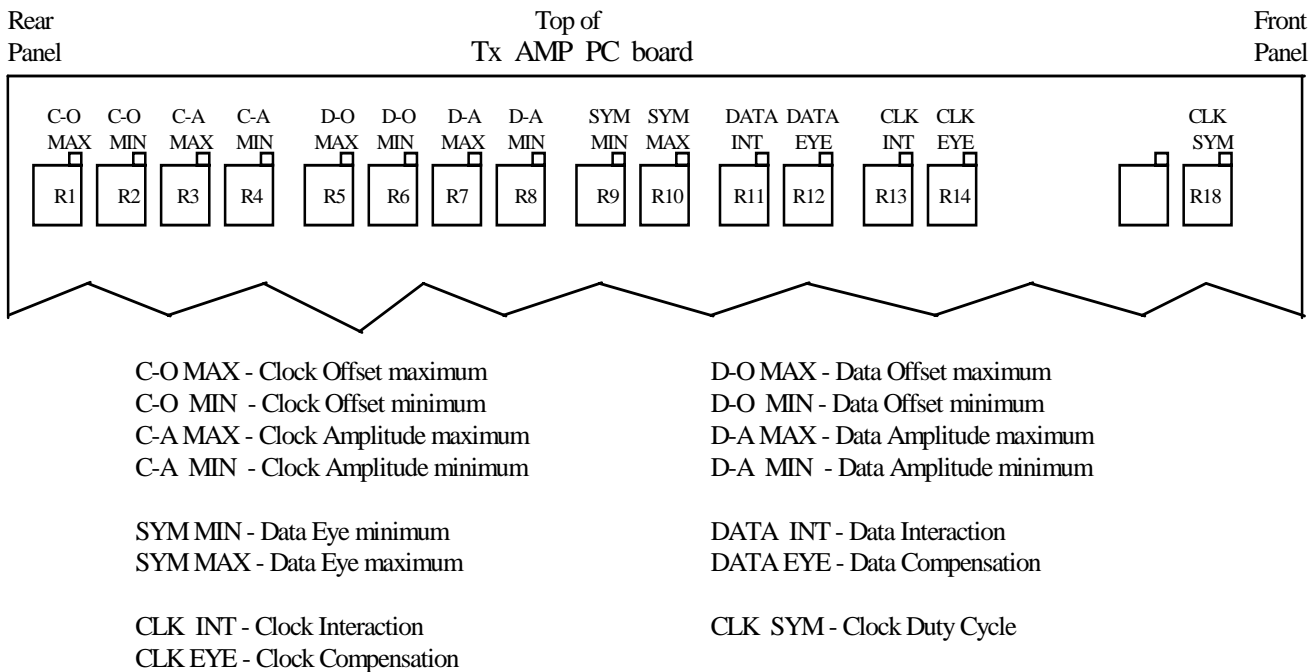

**Figure 9: Placement of adjustment pots on the Tx AMP PCB**

6. The next adjustment is the baseline interaction. The interaction calibrates the baseline so that it remains at the same voltage when the amplitude is varied.
7. Touch CURSOR on the scope screen (located above the grid).
8. Touch CURSOR TYPE.
9. Select HORIZONTAL BARS and exit the menu. You should now see two horizontal red lines on the scope screen.
10. Using the bottom dial, raise the bottom cursor to line up with the bottom of the clock waveform.
11. To adjust the cursor more accurately, perform the following steps.
  - A. Touch CURSOR 1.
  - B. Select FINE and exit the menu.
12. Once the cursor is accurately set along the base line of the clock waveform, raise the clock amplitude on the transmitter to 2.00V while watching the base line.
13. The base line should never leave the line of the cursor. If it does move, the interaction pot must be adjusted.
14. The clock interaction pot on the Tx AMP board is R13 and is labeled CLK INT.
15. Watching the clock signal on the screen, turn the pot until the base line of the waveform is once again on the cursor line.
16. Watching the scope, lower the clock amplitude of the transmitter to 0.50V. The baseline should not move from the cursor line. If the baseline is not matched with the cursor line, return to Step 10 and repeat the procedure until the baseline does not move.
17. Once the baseline is stationary, the interaction is calibrated. Touch exit to return to the measurement menu.
18. The last adjustments are the amplitude and offset. These are done in conjunction.
19. There are four pots, two for amplitude and two for offset, on the Tx AMP board. The MAX pots are for calibration of the maximum amplitude and maximum offset. The MIN pots are for calibration of the minimum amplitude and the minimum offset. Refer to Figure 13 for the location of these pots.
20. The AMPLITUDE value on the scope screen represents the amplitude of the waveform. The MIN value on the scope screen represents the offset of the waveform.
21. On the front panel of the transmitter, set the clock amplitude is 0.50V and the clock offset is -1.00V.
22. On the scope, the value of the AMPLITUDE should be 50.000mV ( $\pm 5$ mV). If the value is out of this range, turn pot R4 (C-A MIN) until the value is within the correct range.
23. On the transmitter, set the clock amplitude to 2.00V.
24. On the scope, the value of AMPLITUDE should be 200.000mV ( $\pm 5$ mV). If the value is out of this range, turn pot R3 (C-A MAX) until the value is within the correct range.
25. On the transmitter, set the clock amplitude to 1.00V & the offset to -2.00V.

26. On the scope, the value of MIN should be  $-200.000\text{mV} (\pm 5\text{mV})$ . If the value is out of this range, turn pot R2 (C-O MIN) until the value is within the correct range.
27. On the transmitter, set the clock offset to 1.00V.
28. On the scope, the value of MIN should be  $100.000\text{mV} (\pm 5\text{mV})$ . If the value is out of this range, turn pot R1 (C-O MAX) until the value is within the correct range.
29. The clock waveform adjustments have now been made. Continue this procedure to set the calibration adjustments for the compensation, interaction, amplitude, and offset of the data waveform.

### ***Data Adjustments***

There are four different values that must be calibrated for the data outputs. These values are compensation, interaction, amplitude, and offset. The compensation and interaction are set once. The amplitude and offset are set once and may be slightly adjusted at several other setting combinations.



---

*Note: It is imperative that these steps are done in the order that they are explained and only if necessary. Each of the adjustments affects the others. If one adjustment is wrong, all the adjustments are affected, making them all wrong. Make these adjustments only if absolutely necessary. If one adjustment appears to be correct, leave it alone and proceed to the next one. The waveform calibrations are very sensitive and can be set wrong very easily. Also, these pots were all adjusted at the factory, therefore if there is drift, the pot adjustments needed should be very small. If you are making major turn adjustments on the pots there is likely something else wrong.*

---

All of the pots necessary for this calibration appear on the Tx Amp board. Use Figure 8 as a reference guide for finding the Tx Amp board. Use Figure 9 as a reference guide to the calibration pots on the Tx Amp board.

1. Data compensation will be the first adjustment made. Compensation is used to minimize the overshoot of the signal while optimizing the rise and fall times of the signal. ***This adjustment also has the greatest effect on the amplitude and offset.*** If the compensation is over-adjusted, the other pots will not be enough to neutralize its effect on the waveform.
2. The compensation only needs to be adjusted if, during the waveform test, the clock failed one of the following conditions.
  - A. Rise Time
  - B. Fall Time
  - C. Overshoot
  - D. Undershoot
3. The pot that controls data compensation is pot R12 and is labeled DATA EYE.
4. Set the data waveform on channel 2 of the scope so that at least one full cycle is visible on the scope screen.

5. Carefully turn pot R12 and observe the waveform change shape. The desired signal shape is a wave that has the largest possible amplitude and an offset with a constant base line. Gauge the best position with your eye.
6. The next adjustment is the baseline interaction. The interaction calibrates the baseline so that it remains at the same voltage when the amplitude is varied.
7. Touch CURSOR on the scope screen (located above the grid).
8. Touch CURSOR TYPE.
9. Select HORIZONTAL BARS and exit the menu. You should now see two horizontal red lines on the scope screen.
10. Using the bottom dial, raise the bottom cursor to line up with the bottom of the data waveform.
11. To adjust the cursor more accurately, perform the following steps.
  - C. Touch CURSOR 1.
  - D. Select FINE and exit the menu.
12. Once the cursor is accurately set along the base line of the data waveform, raise the data amplitude on the transmitter to 2.00V while watching the base line.
13. The base line should never leave the line of the cursor. If it does move, the interaction pot must be adjusted.
14. The data interaction pot on the Tx AMP board is R11 and is labeled DATA INT.
15. Watching the data signal on the screen, turn the pot until the base line of the waveform is once again on the cursor line.
16. Watching the scope, lower the data amplitude of the transmitter to 0.50V. The baseline should not move from the cursor line. If the baseline is not matched with the cursor line, return to Step 10 and repeat the procedure until the baseline does not move.
17. Once the baseline is stationary, the interaction is calibrated. Touch exit to return to the measurement menu.
18. The last adjustments are the amplitude and offset. These are done in conjunction.
19. There are four pots, two for amplitude and two for offset, on the Tx AMP board. The MAX pots are for calibration of the maximum amplitude and maximum offset. The MIN pots are for calibration of the minimum amplitude and the minimum offset. Refer to Figure 13 for the location of these pots.
20. The AMPLITUDE value on the scope screen represents the amplitude of the waveform. The MIN value on the scope screen represents the offset of the waveform.
21. On the front panel of the transmitter, set the data amplitude is 0.50V and the data offset is -1.00V.
22. On the scope, the value of the AMPLITUDE should be 50.000mV ( $\pm 5$ mV). If the value is out of this range, turn pot R8 (D-A MIN) until the value is within the correct range.
23. On the transmitter, set the data amplitude to 2.00V.

24. On the scope, the value of AMPLITUDE should be 200.000mV ( $\pm 5$ mV). If the value is out of this range, turn pot R7 (D-A MAX) until the value is within the correct range.
25. On the transmitter, set the data amplitude to 1.00V & the offset to -2.00V.
26. On the scope, the value of MIN should be -200.000mV ( $\pm 5$ mV). If the value is out of this range, turn pot R6 (D-O MIN) until the value is within the correct range.
27. On the transmitter, set the data offset to 1.00V.
28. On the scope, the value of MIN should be 100.000mV ( $\pm 5$ mV). If the value is out of this range, turn pot R5 (D-O MAX) until the value is within the correct range.
29. The data waveform adjustments have now been made. Return to the *Transmitter Verification* and perform the *Waveform Test* to verify that the calibration is now correct.

### Data Eye Adjustment

This procedure calibrates the data eye crossing. To perform this calibration a simple manual adjustment will be made. A hand-held DVM and a small flat-bladed screwdriver are the only required equipment.

1. Place the ground probe of the DVM in one of the holes in the top of the chassis.
2. Place the positive probe of the DBM onto R43 of the Tx AMP board.
3. Using the small screwdriver, set pot R9 of the Tx AMP board to -2.00V and set R10 to -6.00V.
4. The data eye adjustment has now been made. Return to the *Transmitter Verification* and perform the *Data Eye Crossing* to verify that the calibration is now correct.

### Clock Duty Cycle Calibration

This procedure calibrates the clock symmetry, or duty cycle. The scope, trigger cable, matched coax cables, and a small screwdriver are the required equipment.

1. Obtain a printout of the failing test (or display it on the computer screen) and scan it until you have found the first error.
2. Connect channel 1 of the scope to CLOCK of the transmitter.
3. Connect the trigger cable of the scope to PATTERN SYNC of the transmitter.
4. On the scope, press MEASURE and then touch DUTY CYCLE.
5. Set the frequency of the transmitter to the frequency of the first failure.
6. Verify that the DUTY CYCLE measurement on the scope is outside of the limits shown on the test printout.
7. Adjust pot R18 on the Tx AMP board until the duty cycle is within the given limits.



---

*Note: The scope is set for Average mode. After the pot is turn, wait a moment for the waveform to settle on the scope before reading the duty cycle measurement.*

---

8. Repeat from Step 5 for each failure of the test.
9. The clock duty cycle is now calibrated. Return to the Transmitter Verification and perform the Clock Duty Cycle Test to verify that the calibration is now correct.

### Clock Accuracy Adjustment

This procedure calibrates the clock frequency. The only required equipment is a coax cable, a small flat-bladed screwdriver, and the frequency counter.

1. Attach a cable between the frequency counter and CLOCK of the transmitter.
2. On the transmitter, set the frequency for 1405MHz.
3. The calibration pot for the frequency is on the PLL board. Use Figure 12 to locate the PLL board.
4. On the PLL board, there is a large crystal in a square silver case on the top edge of the board. There is a hole in the top casing of the crystal. Inside this hole is a pot.
5. Using the frequency counter as a guide, turn the pot inside the crystal until the frequency counter reads 1405MHz.
6. The calibration of the clock frequency is now complete. Return to the *Transmitter Verification* and perform the *Clock Accuracy Test* to verify that the calibration is now correct.

## Receiver Calibration

Now that the GB1400 receiver has been verified, those sections that failed must be calibrated. As in the Receiver Verification section, each procedure is its own section. In order to calibrate the receiver, a calibrated transmitter must be available for use. Apply power to the receiver and the calibrated transmitter and allow them at least twenty minutes to warm-up before beginning calibration.

### Threshold Calibration

The input switching threshold levels for the receiver are calibrated in this section. A GB1400 transmitter, the four matched coax cables, the DVM, and a small flat-bladed screwdriver are the only required equipment.

This calibration concerns the adjustment of four different pots found on the Rx InAmp board. Two pots are for the data threshold (maximum and minimum) and two for the reference data threshold (maximum and minimum). Use Figure 10 to find the location of the Rx InAmp board. Use Figure 11 to find the location of the four pots. Note that there are test points for both data and reference data on the Rx InAmp board as well.

1. On the transmitter, remove the terminator from CLOCK BAR.
2. Using the four matched cables, link the transmitter and receiver together as follows.
  - A. Connect the transmitter CLOCK OUT to the receiver CLOCK IN.
  - B. Connect the transmitter CLOCK BAR OUT to the receiver CLOCK BAR IN.
  - C. Connect the transmitter DATA OUT to the receiver DATA IN.
  - D. Connect the receiver DATA BAR IN to VTHRESH on the rear panel of the receiver.
3. On the front panel of the receiver, disable the Auto Search mode (the green light within the LED for AUTOSEARCH should be off).
4. On the receiver, set the threshold level of data to +1.00V.
5. Place the ground probe of the DVM into one of the holes in the top of the chassis.
6. Place the positive probe of the DVM on the test point for data (the shaded circle over DT1 in Figure 15).
7. The measurement on the DVM should equal 1.00V. If the threshold is not correct, then turn pot R9 (DATA MAX) on the Rx InAmp board until the threshold is within the correct limits.
8. On the receiver, change the data threshold to -1.50V.
9. Place the positive probe of the DVM on the test point for data (the shaded circle over DT1 in Figure 15).
10. The measurement on the DVM should equal -1.50V. If the threshold is not correct, then turn pot R13 (DATA MIN) on the Rx InAmp board until the threshold is within the correct limits.

11. On the receiver, press F3 (red LED within the switch should now be lit) to select the reference data settings.
12. On the receiver, change the reference data threshold to +1.00V.
13. Place the positive probe of the DVM on the test point for reference data (the shaded circle over RT1 in Figure 15).
14. The measurement on the DVM should equal 1.00V. If the threshold is not correct, then turn pot R10 (REF DATA MAX) on the Rx InAmp board until the threshold is within the correct limits.
15. On the receiver, change the reference data threshold to -1.50V.
16. Place the positive probe of the DVM on the test point for reference data (the shaded circle over RT1 in Figure 15).
17. The measurement on the DVM should equal -1.50V. If the threshold is not correct, then turn pot R12 (REF DATA MIN) on the Rx InAmp board until the threshold is within the correct limits.
18. The calibration of the receiver threshold is now complete. Return to the *Receiver Verification* and perform the *Threshold Test* to verify that the calibration is now correct.

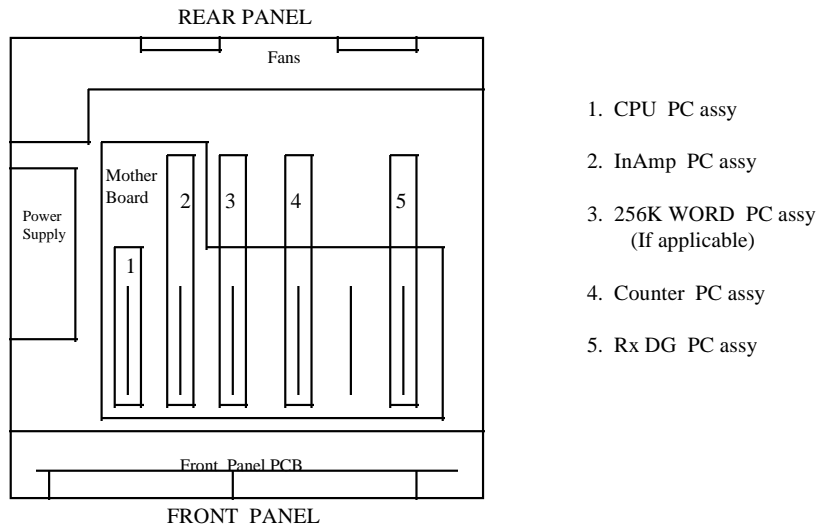

**Figure 10: Placement of PCBs inside the receiver chassis**

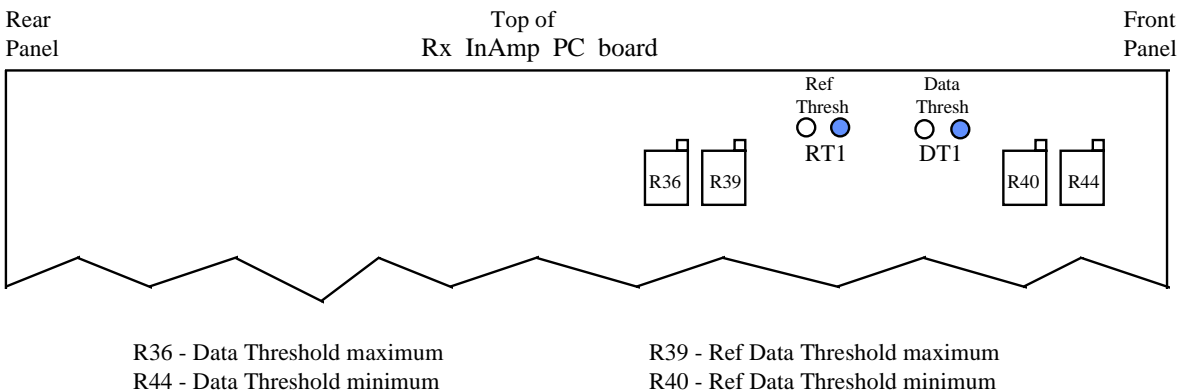

**Figure 11: Placement of the adjustment pots on the Rx InAmp board**

## System Verification

The System Verification is an automated GPIB test that verifies the calibration and proper operation of the GB1400. Follow the steps below to run the System Verification test. A companion GB1400 Transmitter or Receiver must be available for this test (you must have a pair of units). Connect the GB1400 transmitter, GB1400 receiver, and the computer together with GPIB cables.

1. Using the matched coax cables, connect the transmitter and receiver together as follows.
  - A. Connect the transmitter CLOCK OUT to the receiver CLOCK IN.
  - B. Connect the transmitter CLOCK BAR OUT to the receiver CLOCK BAR IN.
  - C. Connect the transmitter DATA OUT to the receiver DATA IN.
  - D. Connect the transmitter DATA BAR OUT to the receiver DATA BAR IN.
2. On the computer keyboard, type 'BERT 1400' and press <ENTER> to start the test program.
3. On the computer keyboard, press F4 to enable the Autosearch Test and then press F9 to start the test.



---

*NOTE: If you wish the results to be written to the A-drive, also press F7 before pressing F9.*

---

4. The cable connection instructions are given at the beginning of each test as required. Verify, when these instructions appear on the screen, that the cable connections are correct. When all connections have been verified, press <ENTER> to continue the test.
5. As the test progresses, the test data will be displayed on the computer screen. When the test is complete, the software returns to the menu screen.
6. The computer now shows a connection diagram of cables on the screen. Connect the cables to the unit as shown in the diagram.

If the test runs successfully, the GB1400 has been successfully calibrated. Proceed to the next section, *Final Clean-up*, to reassemble the unit. A blank calibration data report form is provided with these instructions and may also be found in this section.

## Final Clean-Up

This section of the procedure provides instructions for reassembling the covers of the unit, as well as the blank calibration data report form and instructions for cleaning optical cables and connectors.

## Outside Covers

This section replaces the inner top cover and the outside covers of the unit. A Phillips screwdriver is the only equipment required.

1. Set the inner top cover in place over the top of the chassis.
2. Using the Phillips screwdriver, install the Phillips screws (#6-32 x 3/8"), along each edge of the inner top cover. Tighten all of the screws securely.
4. Place the rear bezel on the bench top with the feet down.
5. Set the rear panel of the GB1400 chassis into the rear bezel.
6. Firmly set the top cover into the slots in the rear bezel. The ventilation holes in the top cover should be at the front panel.
8. Firmly set the bottom cover into the slots in the rear bezel. The ventilation holes in the bottom cover should be at the rear bezel.
9. Place the front bezel over the front panel. Make sure that the top and bottom covers fit into the slots in the front bezel.
10. Using a Phillips screwdriver and the bezel screws, secure the bezels in place. There should be no gaps around the front panel once the screws are tightened securely. You may have to press down on the bezel while tightening the bezel screws.
11. Install a Round Calibration Void label (Part #001-0889-01) over each of the four bezel screws.
12. You have now finished the reinstallation of the outer covers.

## Label Installation

Now that the unit is completely calibrated and all of the covers have been reinstalled, a new calibration label (Part #000-7294-00) may be placed on the unit. Place the unit on the bench with the front panel facing you. Write the appropriate information on the label and remove the backing. The label should be located on the top left-hand corner of the front bezel.

## Calibration Report

The following form may be copied and used to record calibration and testing history for each unit on which this procedure is performed.



**Table 1: GB1400 Transmitter/Receiver Calibration Report**

GB1400Tx Serial Number:	GB1400Rx Serial Number:
Calibration Date:	Temperature and Relative Humidity:
Calibration Performed by:	Date of Calibration:

**GB1400 Tx/Rx Functional Tests**

Test	Passed	Failed
Functional Test		

**GB1400 Transmitter Calibration Tests**

Test	Passed	Failed
Waveform Test		
Data Eye Test		
Clock Duty Cycle Test		
Clock Accuracy Test		

**GB1400 Receiver Calibration Tests**

Threshold	Nominal Value	Minimum	Measured Value	Maximum
Data Thresh, Minimum	-1.50V	-1.50V		-1.49V
Data Thresh, Maximum	+1.00V	+0.99V		+1.00V
Reference Data Thresh, Minimum	-1.50V	-1.50V		-1.49V
Reference Data Thresh Maximum	+1.00V	+0.99V		+1.00V

